

DO NOT touch this adjustment.
 This is preset by the manufacturer, and is NOT for field service. Conventional carb. cleaners will not affect the sealant securing this adjustment.

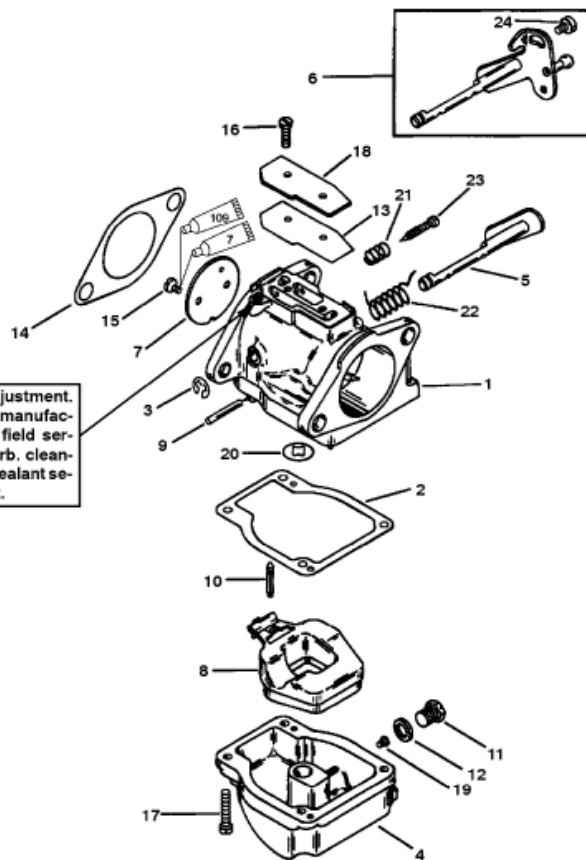

Quicksilver Lubrication/Sealant
 Application Points

- Loctite 271 (Obtain Locally)
- Loctite Primer "T" (92-59327-1)

Parts List						
Ref	Class	Part	Description	Qty	Comment	Footnote
1	3301	821679A34	CARBURETOR	1	100 - WME-32/32A	
1	3301	821679A35	CARBURETOR	1	100 - WME-32/32A	
1	3301	821679A36	CARBURETOR	1	100 - WME-32/32A	
1	3301	821679A37	CARBURETOR	1	100 - WME-32/32A	
1	3301	821946A10	CARBURETOR	1	115 - WME-33	
1	3301	821946A11	CARBURETOR	1	115 - WME-33	
1	3301	821946A12	CARBURETOR	1	115 - WME-33	
1	3301	821946A13	CARBURETOR	1	115 - WME-33	
1	3301	824902A 9	CARBURETOR	1	115 - WME-40/40A	
1	3301	824902A10	CARBURETOR	1	115 - WME-40/40A	
1	3301	824902A11	CARBURETOR	1	115 - WME-40/40A	
1	3301	824902A12	CARBURETOR	1	115 - WME-40/40A	
1	3301	821680A 1	CARBURETOR	1	125 - WME-34	
1	3301	821680A 2	CARBURETOR	1	125 - WME-34	
1	3301	821680A 3	CARBURETOR	1	125 - WME-34	
1	3301	821680A 4	CARBURETOR	1	125 - WME-34	
2			GASKET-FUEL BOWL	4		10,11
3			RETAINING RING	4		10
4	1395	811693	FUEL BOWL	AR		9
4	1395	811696	FUEL BOWL	1	(WME-40-TOP)	
5	1395	823632	THROTTLE SHAFT	3	(WME-1/3/4)	
6	1395	823632 1	THROTTLE SHAFT	1	(WME-2)	
7	1395	9724 1	THROTTLE VALVE	4		
8	1395	9594	FLOAT	4		
9		F10064	FLOAT SHAFT	4		10
10	1395	9595 1	INLET NEEDLE VALVE	4		10
11	1395	811694	PLUG	4		
12	1395	802731	SEAL (CONSISTS OF 4 SEALS)	1		10
13			GASKET-COVER PLATE	4		10,11
14	27	15172 3	GASKET-FLANGE	4		1,11
15	10	F10155	SCREW-THROTTLE VALVE	8		
16	1395	811220	SCREW-COVER PLATE	8		
17	1395	808612	SCREW-FUEL BOWL	16		
18	1395	811221	COVER PLATE	4		
19	1399	5317	MAIN FUEL JET (.046)	1	(WME-32-1/32A-1)	
19	1395	6246	MAIN FUEL JET (.048)	1	(WME-32-2)	
19	1395	6028	MAIN FUEL JET (.050)	1	(WME-33-1/32A-2)	
19	1395	6359	MAIN FUEL JET (.052)	2	(WME-32-3/4)	
19	1399	5225	MAIN FUEL JET (.054)	1	(WME-32A-3)	
19	1399	5213	MAIN FUEL JET (.056)	2	(WME-33-2/3/32A-4)	
19	1399	4317	MAIN FUEL JET (.062)	1	(WME-33-4)	